

TANG BAND W5-1611SAF Analysis TABAQ type shape

By Bjørn Johannesen, Bredkær 11, bjohannesen@post.cybercity.dk, 2650 Hvidovre, Denmark using simulation software which is the property right of Martin J. King www.quarter-wave.com

This driver will do well in an enclosure layout like TABAQ: A straight line with two sections. The last part has a much smaller cross section and is made as a folded opening at the bottom of the cabinet – like TABAQ. Please note that the material in the front baffle is included in the length of the aperture.

Driver T/S

$f_d := 60 \text{ Hz}$	$V_{ad} := 11.69 \text{ liter}$
$R_e := 6.3 \text{ } \Omega$	$Q_{ed} := 0.52$
$L_{vc} := 0.023 \text{ mH}$	$Q_{md} := 2.8$
$Bl := 5.53 \frac{\text{newton}}{\text{amp}}$	$Q_{td} := \left(\frac{1}{Q_{ed}} + \frac{1}{Q_{md}} \right)^{-1}$
$S_d := 94 \text{ cm}^2$	$Q_{td} = 0.439$

Internal geometry and stuffing

Closed End of Transmission Line (Driver ---> Closed End)

Section Length	Initial Area	Final Area	Stuffing Density
$L_{c_0} := 15 \text{ in}$	$S_{c_{0,0}} := 3 S_d$	$S_{c_{0,1}} := 3 S_d$	$D_{c_0} := 0.6 \text{ lb} \cdot \text{ft}^{-3}$

Open End of Transmission Line (Driver ---> Open End)

Section Length	Initial Area	Final Area	Stuffing Density
$L_{o_0} := 15 \text{ in}$	$S_{o_{0,0}} := 3 S_d$	$S_{o_{0,1}} := 3 S_d$	$D_{o_0} := 0.6 \text{ lb} \cdot \text{ft}^{-3}$
$L_{o_1} := 15 \text{ in}$	$S_{o_{1,0}} := 3 S_d$	$S_{o_{1,1}} := 3 S_d$	$D_{o_1} := 0.1 \text{ lb} \cdot \text{ft}^{-3}$
$L_{o_2} := 5.0 \text{ in}$	$S_{o_{2,0}} := 0.5 S_d$	$S_{o_{2,1}} := 0.5 S_d$	$D_{o_2} := 0.0 \text{ lb} \cdot \text{ft}^{-3}$

Cross section is $3S_d = 282 \text{ cm}^2$, (f.eks. $15 \cdot 18,8$)

opening is $0.5 S_d = 47 \text{ cm}^2$. (f.eks. $15 \cdot 3,1$)

15" = 38,1 cm

5" = 12,7 cm

Total Length of the Transmission Line

$$\sum_{i=0}^{n_{\text{closed}}} L_{c_i} + \sum_{i=0}^{n_{\text{open}}} L_{o_i} = 50.000 \text{ in}$$

Total Amount of Stuffing

$$\left[\sum_{r=0}^{n_{\text{closed}}} \left(\frac{S_{c_{r,0}} + S_{c_{r,1}}}{2} \cdot L_{c_r} \cdot D_{c_r} \right) \right] + \left[\sum_{r=0}^{n_{\text{open}}} \left(\frac{S_{o_{r,0}} + S_{o_{r,1}}}{2} \cdot L_{o_r} \cdot D_{o_r} \right) \right] = 0.455 \text{ lb}$$

Stuffing: Last one third of the line and the opening is not stuffed.

The last narrow part is an extension of the line and can be folded at the bottom of the cabinet like TABAQ.



Tuning is about 43 Hz

This is well below drives Fs, but is possible due to the relatively high Qts.

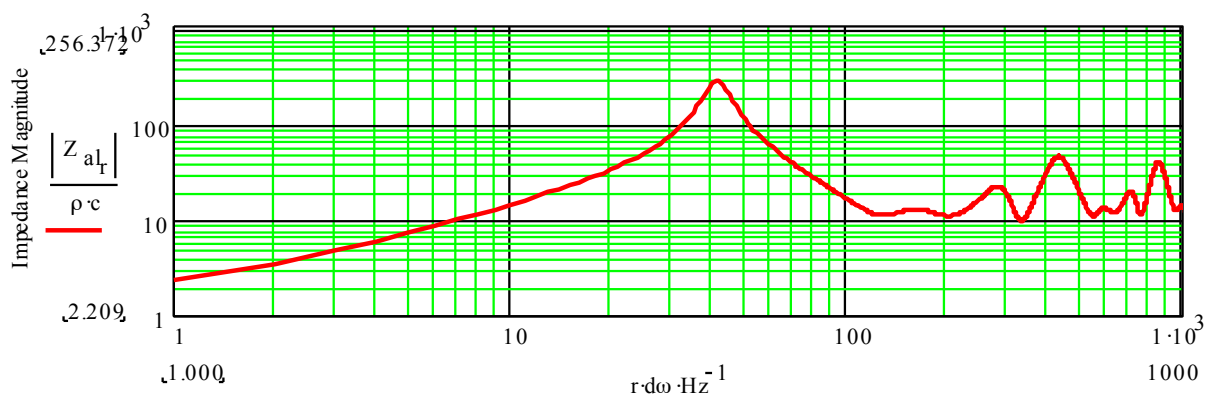

Summed SPL

I would expect usable output down to mid 30-ties.

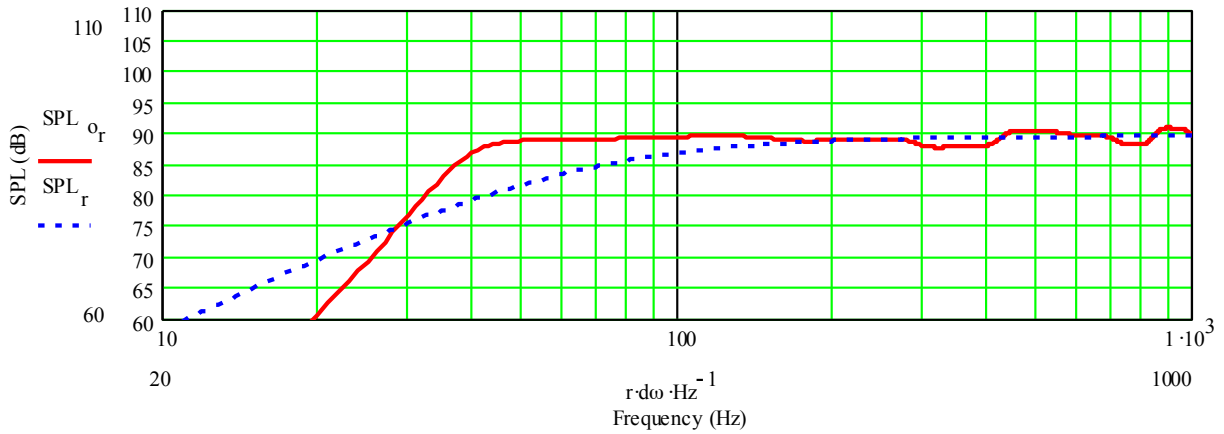

Driver and Opening

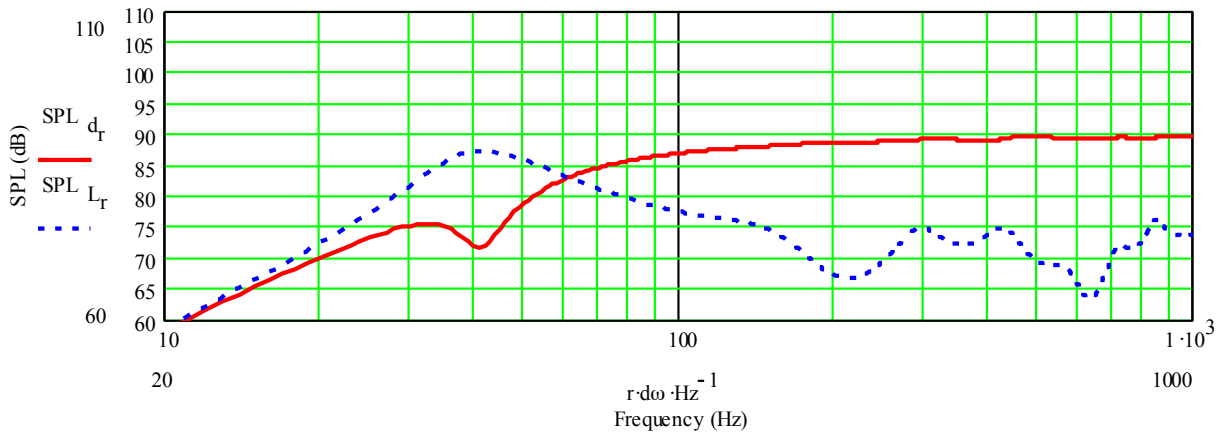

Impedance

Note the double hump with the lower peak damped. Bass reflex would not have this property.

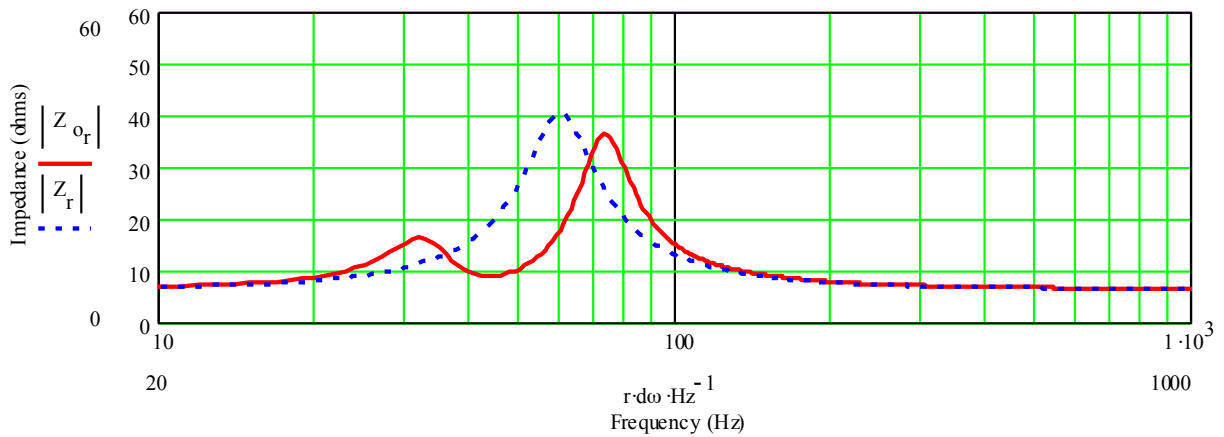

Displacement

Cone movement is controlled.

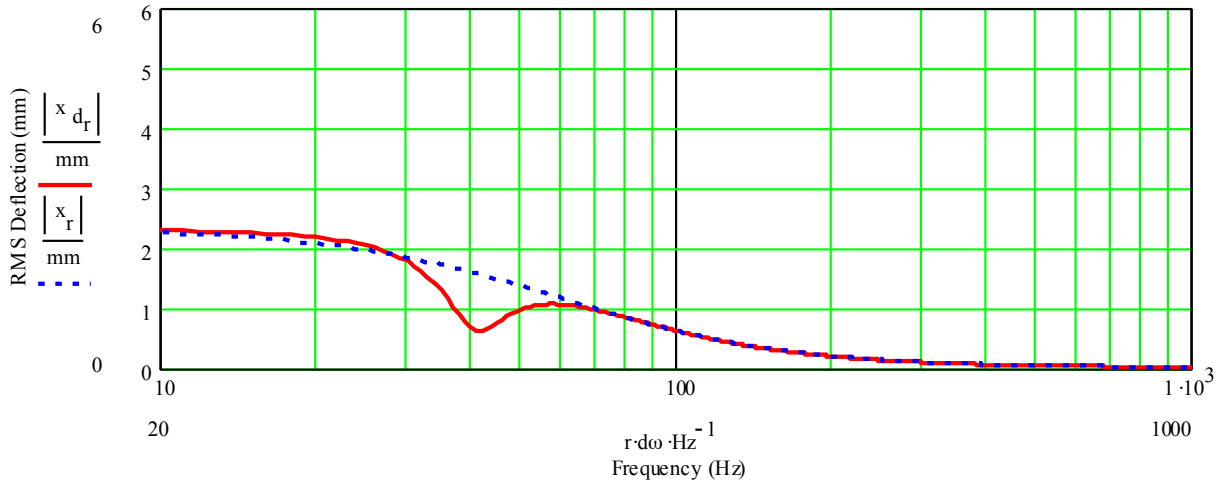

Airspeed at opening

No problems with air flow at the opening.

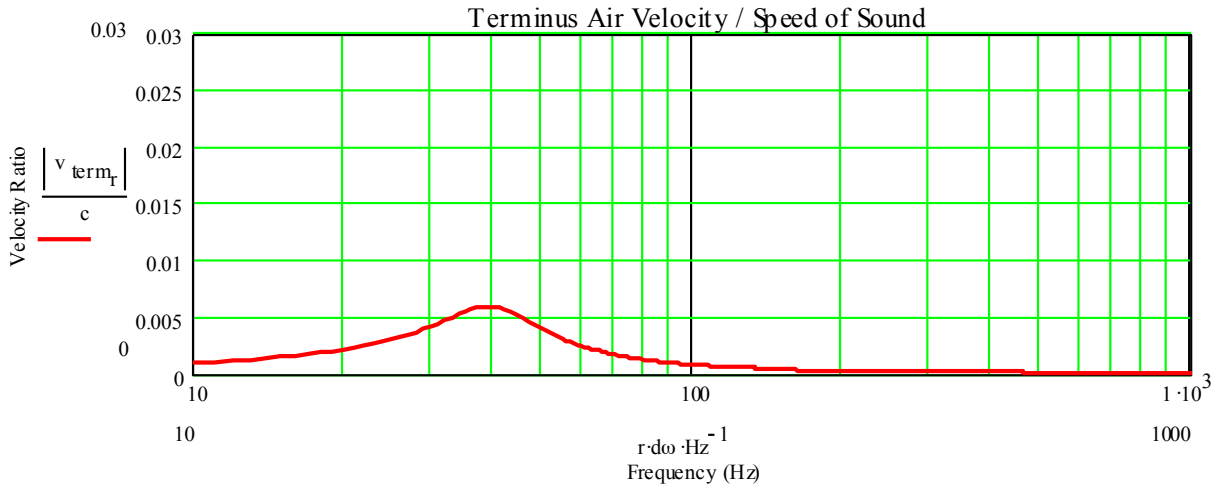

TABAQ LARGE, designed for Tang Band W5-1611SAF

19 mm MDF. Stuffing 200g in upper 2/3 only. BSC to be calculated.

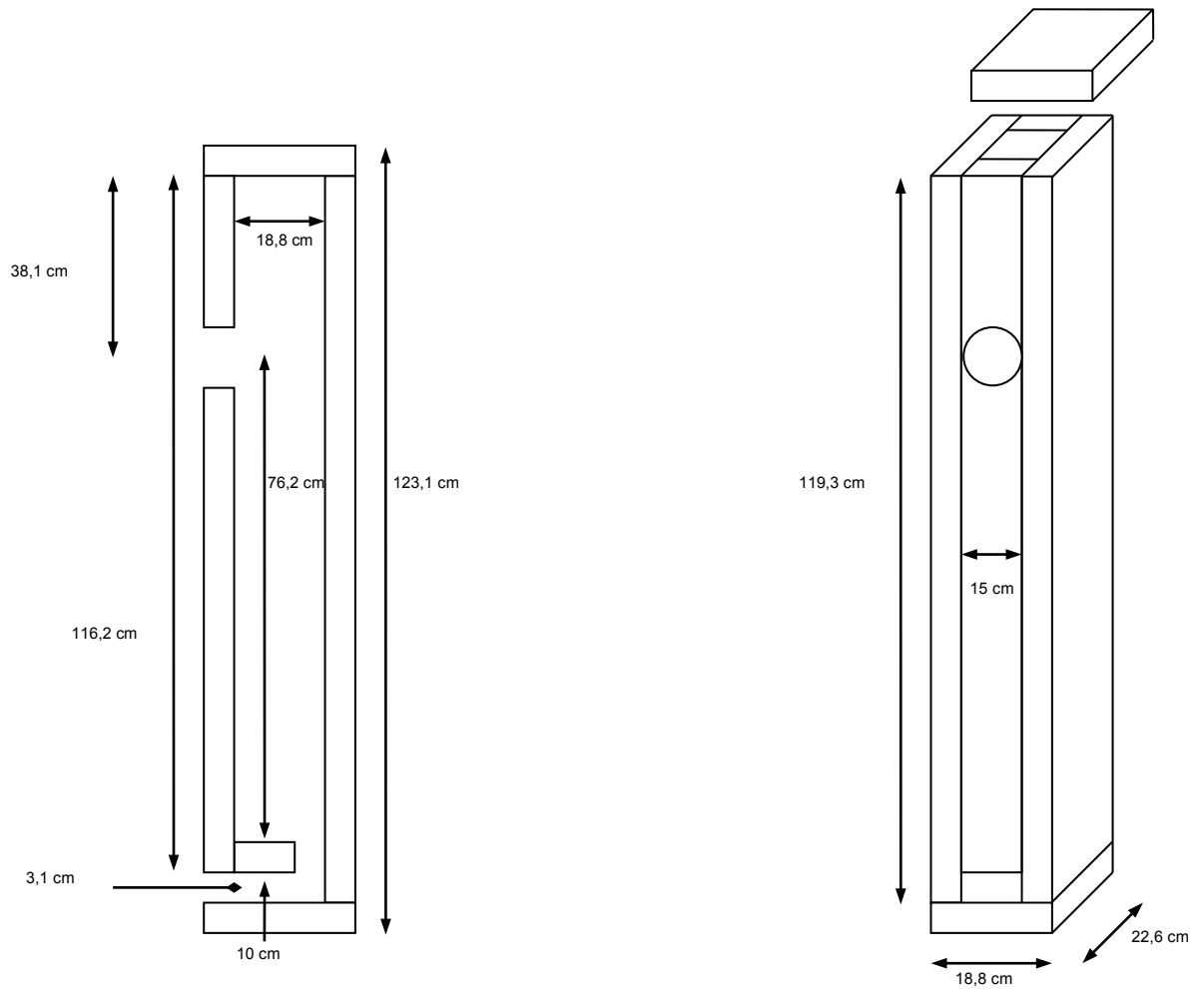

1	15 x 116,2	Front
1	15 x 119,3	Back
2	18,8 x 22,5	Top and Bottom
2	119,3 x 22,5	Side
1	15 x 10	Opening